

Operating Instructions

# Sartorius Pallet Scale/Flat-bed Scale for Use in Hazardous Locations

Models IUXS4... | IFXS4...

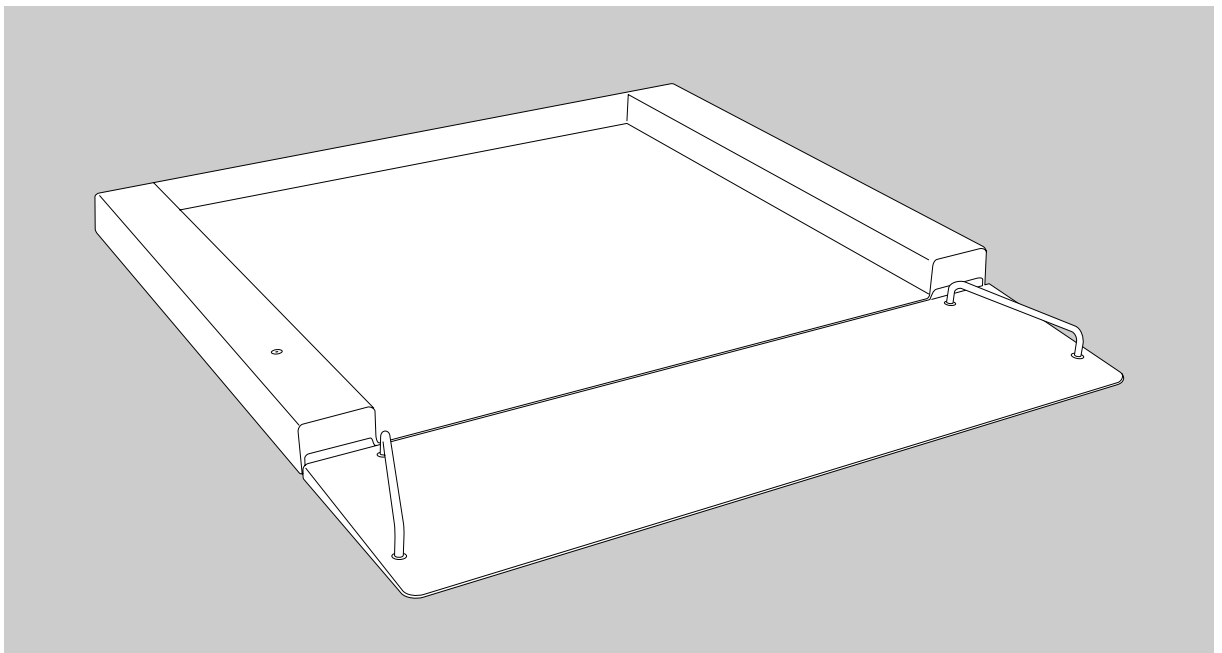
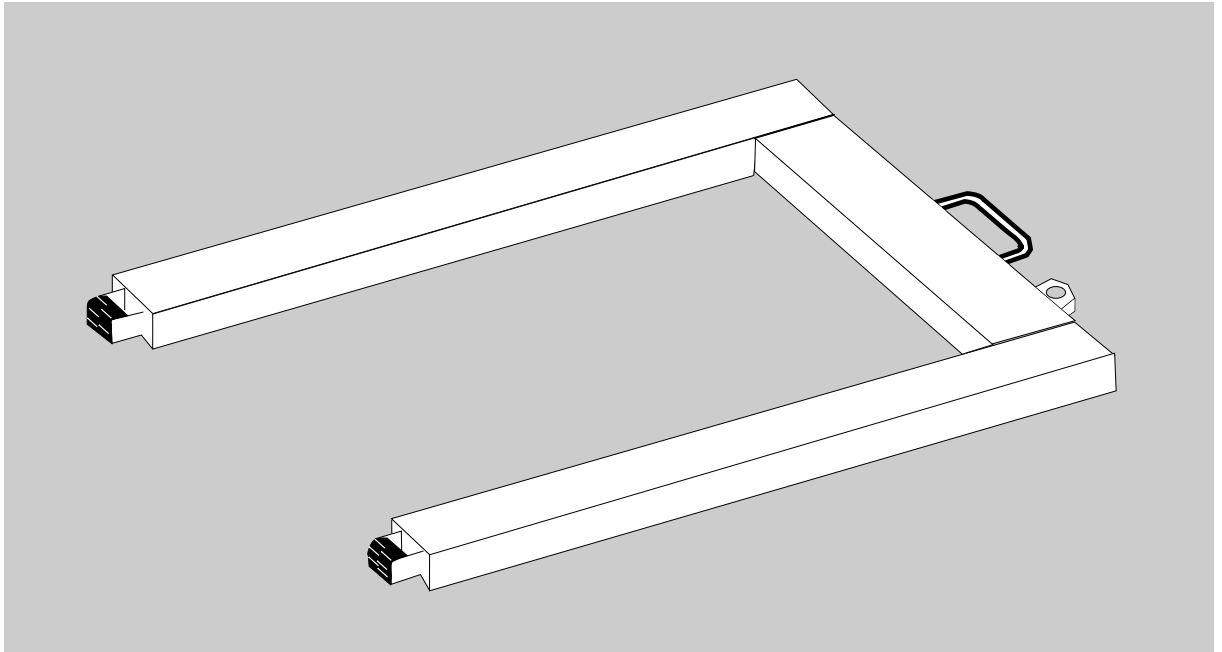

# General View of the Equipment

## IUXS4

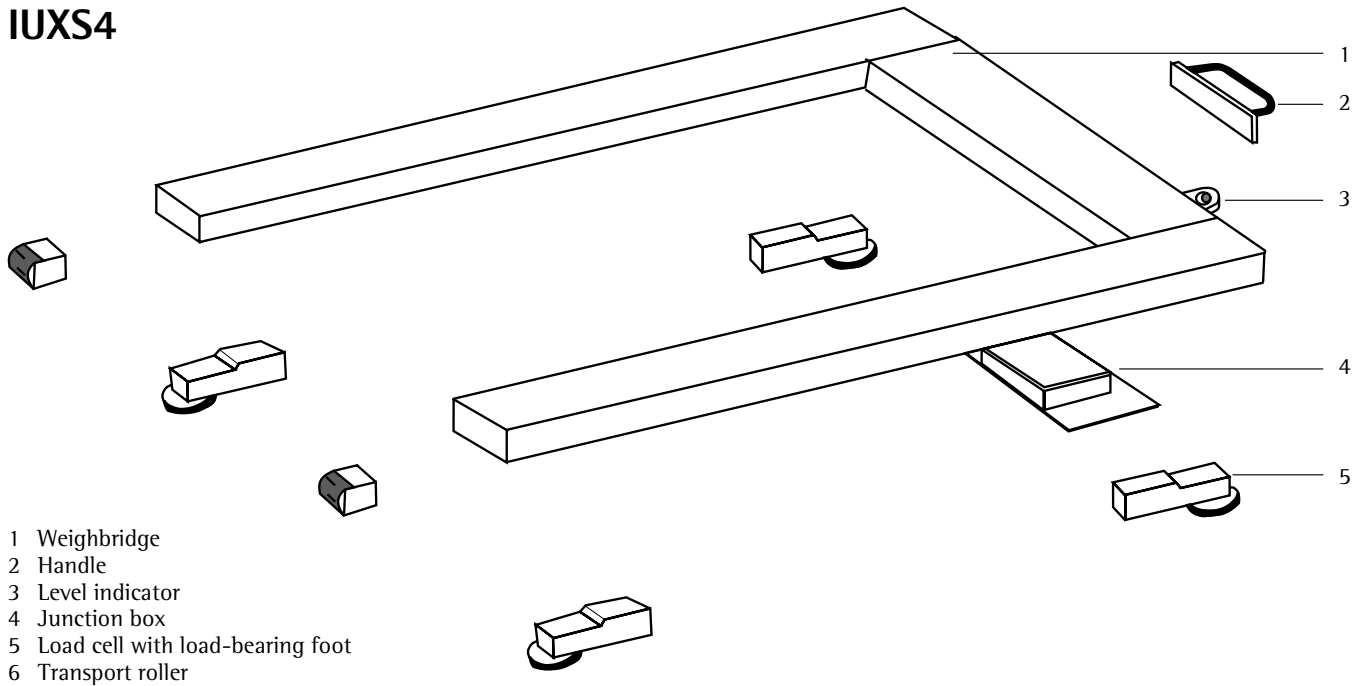

### Configuration Example: IUXS4.. Pallet Scale with Combiics Indicator

## Hazardous Location

## Non-hazardous Location



# General View of the Equipment

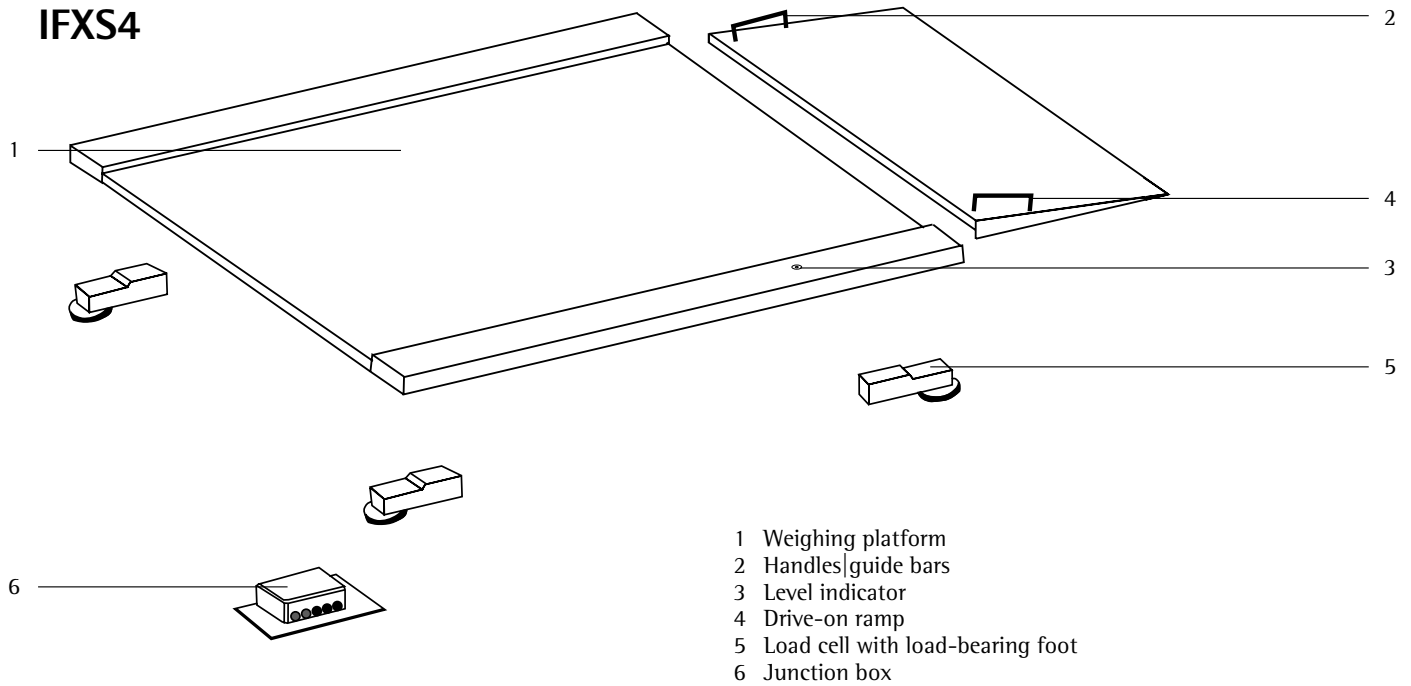

Configuration Example: IFXS4.. Flat-bed Scale with Combics Indicator

## Hazardous Location

## Non-hazardous Location

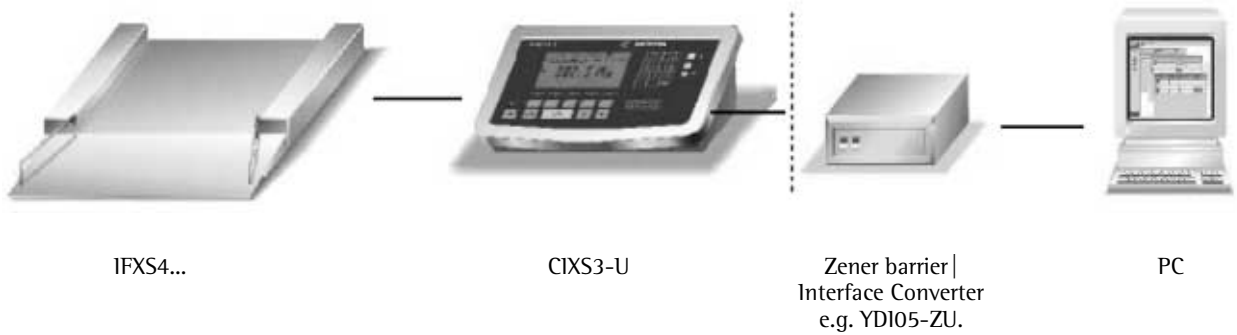

# Contents

- 4 Symbols
- 4 Intended Use
- 4 Warranty
- 5 Safety Instructions
- 6 Setting Up the Scale
- 8 The IFX.. Weighing Platforms
- 10 The IUX.. Weighing Platforms
- 12 Installation Instructions
- 15 Installation of Indicator
- 16 Care and Maintenance
- 17 Certificates of Compliance

## The following symbols are used in these instructions:

- Indicates required steps
- Indicates steps required only under certain conditions
- > Describes what happens after you have performed a certain step
- Indicates an item in a list
- ⚠ Indicates a hazard

Make sure you observe the following warning and safety information in its entirety during installation and operation, as well as while performing maintenance and repair work on the equipment. It is important that all personnel using the Combics equipment understand this information, and have access to it at all times.

Furthermore, the warning and safety information supplied with any electrical equipment connected, such as the indicator, must be observed as well. The warning and safety information can be supplemented by the equipment operator. Make sure all operating personnel are informed of any additions to these instructions.

## Intended Use

The weighing platform and the connected indicator are intended exclusively for use in weighing.

## Warranty

Do not miss out on the benefits of our full warranty. Please contact your local Sartorius office or dealer for further information. If available, complete the warranty registration card, indicating the date of installation, and return the card to your Sartorius office or dealer.

### EMC Declaration

This equipment has been tested in conjunction with Sartorius indicators (e.g., CIXS3-U, FCT01-X) and found to comply with the limits for a Class A digital device, pursuant to Part 15 of the FCC rules. These limits are designed to provide reasonable protection against harmful interference when the equipment is operated in a commercial environment. This equipment generates, uses and can radiate radio frequency energy and, if not installed and used in accordance with the instruction manual, may cause harmful interference to radio communications. Operation of this equipment in a residential area is likely to cause harmful interference in which case the user will be required to correct the interference at his own expense.

**Shielded Cables:** Connections between the devices and peripherals must be made using shielded cables in order to maintain compliance with FCC radio frequency emission limits.

**Modifications:** Any modifications made to this devices that are not approved by Sartorius AG may void the authority granted to the user by the FCC to operate this equipment.

### Model-specific Information: Serial Number Coding

The month and year of manufacture are encoded in the serial number as follows:

Y M M x x x x x

Y = Year:

1	2000–2006
2	2007–2013
3	2014–2020
4	2021–2027
5	2028–2034
6	2035–2041
7	2042–2048
8	2049–2055
9	2056–2062

The first digit represents a 7-year period as indicated in the table above. The next 2 digits represent the month. The months are numbered consecutively, starting with 13, over the entire 7-year period. Thus the number representing the month also indicates the specific year of manufacture.

2000	13–24
2001	25–26

...

Example:

113xxxxx → January 2000

The individual platforms are numbered consecutively in the last 5 digits, starting from 00000 again at the beginning of each month.

# Safety Instructions

The weighing platform is approved/certified by FM Approvals for use in hazardous locations in the USA and in Canada according to FM Approvals and CSA standards, respectively (see enclosed Certificates of Compliance). This intrinsically safe device is suitable for use in Class I, II, III, Division 1 Group A, B, C, D, E, F, G T4, Class I, Zone 1, Group IIC, T4 and Class II, Zone 20, hazardous locations at an ambient temperature range of  $-20^{\circ}\text{C}$  to  $+40^{\circ}\text{C}$  ( $-4^{\circ}\text{F}$  to  $+104^{\circ}\text{F}$ ) (see enclosed Control Drawing 35739-003-07-A4). Division 1 includes Division 2, Zone 1 includes Zone 2, and Zone 20 includes Zones 21 and 22. If the weighing platform is used in Class I, II, III, Division 2 Group A, B, C, D, E, F, G or Class I, Zone 2 or Class II, Zone 22, and is connected to a non-intrinsically safe device, the instructions given on page 2 of the enclosed Control Drawing must be followed.

- The weighing platform can be operated indoors or outdoors.
- Improper use or handling, however, can result in damage and/or injury.
- The installation must be done in accordance with the Control Drawing 35739-003-07-A4 enclosed at the end of this manual.
- If you use this equipment in installations and under ambient conditions requiring higher safety standards, you must comply with the provisions as specified in the applicable regulations for installation in your country.
- Please make sure the currently valid regulations (e.g., National Electrical Code) and standards for installation in the hazardous locations are strictly observed.
- The weighing platform may be used and operated by qualified personnel only. The permitted uses of the weighing platform are specified in the Certificate of Compliance.
- Do not expose the weighing platform to aggressive chemical vapors or to extreme temperatures, moisture, shock, or vibration.
- The permissible temperature range during operation only for the platform is  $-20^{\circ}\text{C}$  to  $+40^{\circ}\text{C}$  ( $-4^{\circ}\text{F}$  to  $+104^{\circ}\text{F}$ ). The accuracy of the platform cannot be guaranteed for higher temperatures.
- Make sure to observe the applicable safety rules and regulations for the prevention of accidents.
- Do not damage the cable junction box or the load cells during transportation.
- Installation in a hazardous location must be performed by a trained technician who is familiar with the assembly and operation of the equipment, as well as with the procedure for putting the system into operation. Furthermore, the trained technician must have the required qualifications and must be familiar with the relevant guidelines and regulations. If you need assistance, contact your local Sartorius dealer or the Sartorius Service Center.
- Any installation work that does not conform to the instructions in this manual will result in forfeiture of all claims under the manufacturer's warranty. Be sure to observe all restrictions listed in the Certificate of Compliance and the enclosed Control Drawing. Operating the weighing platform beyond the limits imposed by these restrictions is not permitted, and is considered use of the equipment for other than its intended purpose.
- Have the equipment inspected at appropriate intervals for correct functioning and safety by a trained technician.
- The junction box may be opened only by authorized service technicians who have been trained by Sartorius and who follow Sartorius' standard operating procedures for maintenance and repair work.
- Always make sure the weighing platform is disconnected from AC power before performing any installation, cleaning, maintenance or repair work. If the equipment housing is opened by anyone other than persons authorized by Sartorius, all claims under the manufacturer's warranty are forfeited. Use only original Sartorius spare parts.
- Handle the equipment in accordance with its protection (IP) rating. The international protection rating of the weighing platform is IP67 (dust-tight and protected against short-term immersion). Do not damage the IP protection when cleaning the equipment. The IP protection rating is ensured only if the rubber gasket is installed on the junction box and all cable gland screw fasteners are connected securely. Any installation work that does not conform to the instructions in this manual will result in forfeiture of all claims under the manufacturer's warranty.
- If you use cables purchased from another manufacturer, check the pin assignments.
- Before connecting the cable to Sartorius equipment, check the pin assignments in the cable against those specified by Sartorius and disconnect any wires that are assigned differently. The operator shall be solely responsible for any damage or injuries that occur when using cables not supplied by Sartorius.
- When using the weighing platform in hazardous locations, make sure there is no current or voltage in the equipment before connecting or disconnecting current carrying cables to or from the platform.
- Disconnect the platform from AC power before connecting or disconnecting cables.
- Avoid exposing the weighing platform to static electricity; be sure to connect the equipotential bonding (grounding) conductor to the junction box. Disconnecting equipotential bonding conductors is not permitted!
- If you see any indication that the weighing platform cannot be operated safely (for example, due to damage), turn off the platform and lock it in a secure place so that it cannot be used for the time being. Observe the relevant safety precautions and inform personnel as required.
- The cable jacket of all connecting cables, as well as the conductors inside the equipment housing, is made of PVC. Chemicals that corrode these materials must be kept away from these cables.
- Make sure the weighing instrument is not exposed to substances that release chlorine ions at the place of use. If such exposure cannot be ruled out, the operator is responsible for establishing and observing appropriate safety precautions, to be checked at regular intervals for continued effectiveness.

## Setting Up the Scale

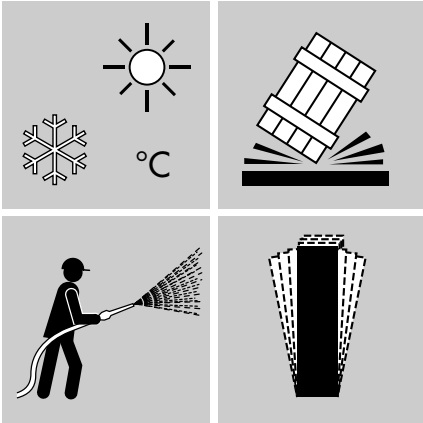

- Choose a suitable place to set up the weighing platform. This place should have a dry, horizontal and even surface. The operating temperature range only for the platform is between  $-20^{\circ}\text{C}$  and  $+40^{\circ}\text{C}$  ( $-4^{\circ}\text{F}$  and  $+104^{\circ}\text{F}$ ). The allowable structural load-carrying capacity of a floor or surface must be sufficient to support both the weight of the weighing platform and its maximum weighing capacity.

If you need to use the weighing platform in areas exposed to heavy traffic (e.g., fork-lift trucks), you should install a protective frame, consisting of angular braces, around the weighing platform.

Do not expose the weighing platform unnecessarily to aggressive chemical vapors or to extreme temperatures, moisture, shock, or vibration, which could result in damage.

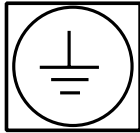

- The air bubble must be centered within the circle on the level indicator.
- If the weighing platform is in a hazardous location, it must be grounded (i.e., an equipotential bonding conductor must be connected). This connection should be made by a trained technician.

All Combics weighing platforms are equipped with a connector for the grounding conductor.

This is located either below the load pan, on the junction box, or on the lower frame of the weighing platform. The position is marked in each case by the symbol shown here, indicating the grounding connection.

The grounding conductor is connected to a threaded bolt or terminal screw, or a drill hole is provided. If a drill hole is provided, use a stainless steel screw and nut to connect the grounding conductor. Use of a tooth lock washer is recommended, to prevent the screw from coming loose. The wire used for the grounding conductor should have a gauge or cross-sectional diameter of at least  $4\text{ mm}^2$  ( $0.006\text{ in}^2$ ), with a suitable ring lug attached. Connect all equipment, including peripheral devices, to the equipotential bonding conductor.

---

### Conditions for Installation in Hazardous Locations

Before putting the equipment into operation, it is important to make sure that the cable of the power supply is correctly connected to the power outlet (mains supply).

All equipment must be connected to the equipotential bonding conductor via grounding cable (not included in delivery) connected to the grounding terminals on each device. The dimensions of the grounding cable are specified in national regulations for electrical installations. Installation must be performed by a trained technician in accordance with national regulations and generally acknowledged rules of engineering.

Use only cabling and extensions approved by Sartorius, as these are made in accordance with the restrictions on permissible cable lengths imposed by both the capacitance and inductivity values (see Control Drawing) and the requirements for electromagnetic compatibility.

Before putting the weighing system into operation for the first time, make sure there is no hazard of explosion present at the place of installation. If there is any indication that the equipment does not function properly (e.g., display remains blank, or no display backlighting) due to damage during transportation, disconnect the equipment from power and notify your nearest Sartorius Service Center.

The weighing platform specifications for Ui, Ii, Pi, Ta, temperature class, Ci and Li are listed in the enclosed Control Drawing. These parameters (Entity Concept) must be taken into account when connecting an indicator to the platform. Sartorius confirms that the Sartorius indicators CIXS3-U and FCT01-X may be connected to these platforms (see Control Drawing and "Verification of Intrinsic Safety" in the manual of the indicator).

The explosion-protected weighing system must be installed in accordance with acknowledged rules of engineering. These include national laws and regulations (e.g., National Electrical Code).

Furthermore, national regulations for accident prevention and environmental protection must be observed at all times.

Before the platform is operated in a hazardous location, it must be inspected either by a certified electrician or under the guidance and supervision of a certified electrician to make sure that the weighing system complies with the applicable regulations. Determine whether the installation must be registered with technical inspection authorities in your country. Regular inspections must also be performed on the system during operation. The system should be inspected at intervals short enough to permit the prevention or early detection of defects that arise as a result of normal wear and tear.

The longest permissible interval period is 3 years. Other conditions and standards that regulate the installation and operation of the equipment and are applicable in your country must be met as well. When performing inspections, generally acknowledged rules of engineering relevant to these conditions must also be applied.

If the terminal housing is opened by anyone other than persons authorized by Sartorius, or if the terminal is installed or operated incorrectly, this will result in forfeiture of the approval for use in the stated hazardous location(s) and of all claims under the manufacturer's warranty.

# The IFX Weighing Platforms

Example of model designation:

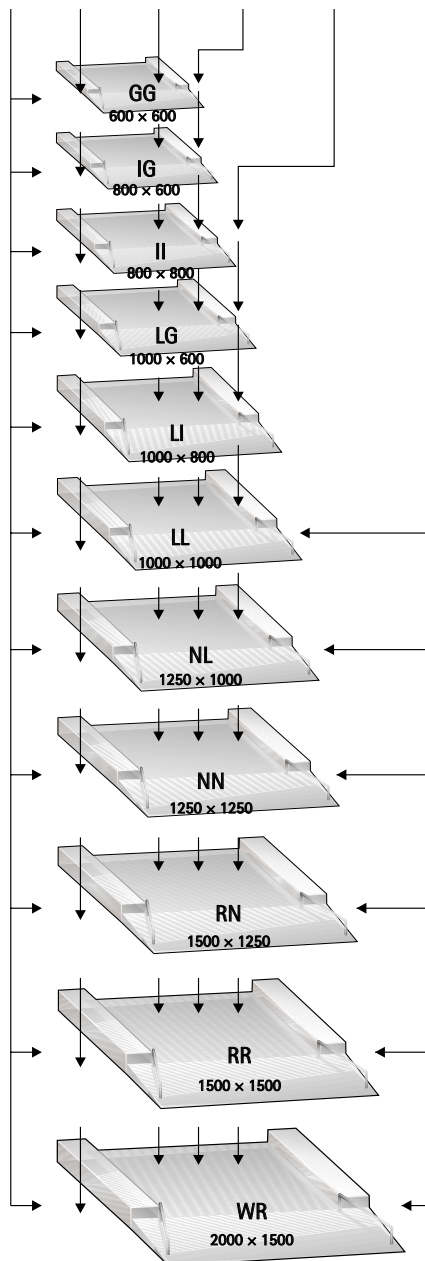
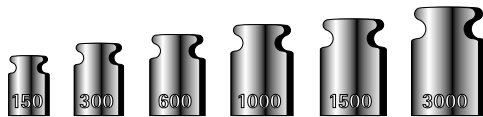
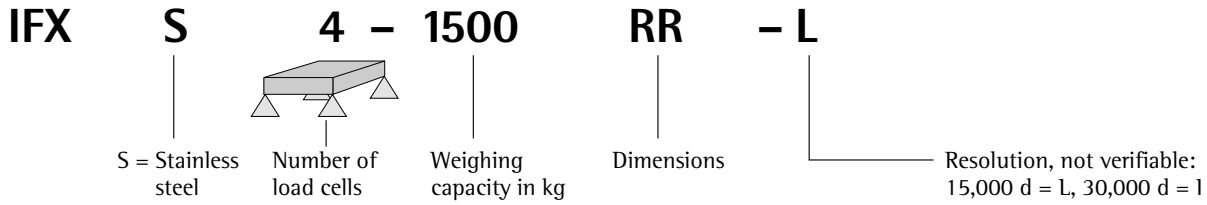

### Stainless steel models:

- Weighing capacities from 150 kg to 3000 kg
- 11 different sizes
- 6 weighing capacities
- 59 models
- 15,000 d, 30,000 d
- Material/surface finishing: AISI 304 or AISI 316 Ti stainless steel, brushed or electropolished
- IP67/IP68 rating
- Stainless steel load cells
- Drive-on ramp; customized versions possible



# Specifications

## General Specifications for the IFXS4... Models

Model	IFXS4...	
Allowable ambient operating	°C	-20 to +40 (-4° to +104°F)
IP protection	IP68 (stainless steel models)	
Length of built-in cable (standard equipment)	m	6

Capacities: Up to 3000 kg, with restrictions, when the load is distributed on the load plate.

## Accessories (Options)

	Order no.
Additional drive-on ramps	Available on request
Frame for pit installation	Available on request
Floor-mounting set for attaching the weighing platform to the floor	YFP011

Columns can be manufactured to order on request.

## Dimensions

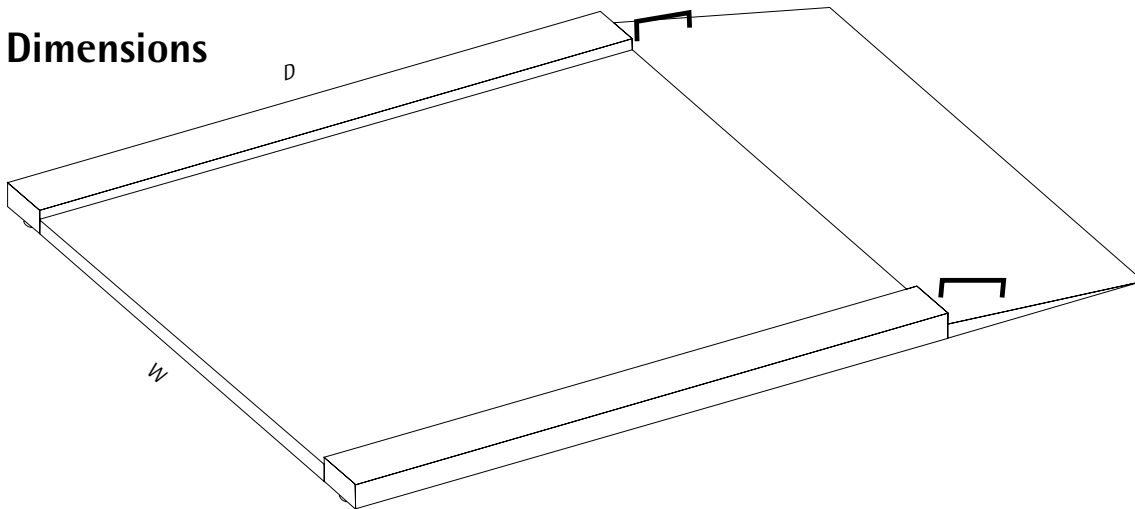

Designation	GG	IG	II	LG	LI	LL	NL	NN	RN	RR	WR
D (mm)	600	800	800	1000	1000	1000	1250	1250	1500	1500	2000
W (mm)	600	600	800	600	800	1000	1000	1250	1250	1500	1500

## Resolutions

Resolution		
Weighing capacity:	-L	-I
Weighing capacity in kg	15,000d in g	30,000d in g
150	10	5
300	20	10
600	50	20
1000	100	50
1500	100	50
3000	200	100

# The IUX.. Weighing Platforms

Key to model designations:

IUX S

S =  
Stainless  
steel

4

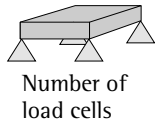

-

3000

Weighing  
capacity  
in kg

NI

Dimensions

-L

Resolution,  
not verifiable:  
15,000 d = L  
30,000 d = I

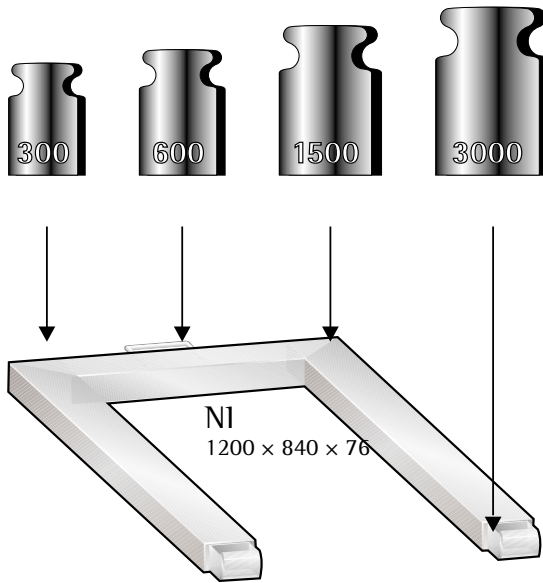

## Stainless steel versions:

- Weighing capacities from 300 kg to 3000 kg
- 1 size: Euro-pallet
- 4 weighing capacities
- 4 models
- 15,000 d, 30,000 d
- Material/surface finishing: AISI type 304 or 316 Ti stainless steel, bead-blasted or electropolished
- IP67/IP68 rating
- Stainless steel load cells
- Customized versions possible

# Specifications

## General Specifications for the IUXS4-... Models

Model	IUXS4-	
Allowable ambient operating temperature For verified models:	°C	-20 to +40 (-4° to +104°F)
IP rating		IP68 (stainless steel models)
Length of built-in cable (on weighing platform; standard equipment)	m	6

Capacities: Up to 3000 kg, with restrictions, distributed load.

## Accessories

	Order no.
For stainless steel versions	
- Inset plate, stainless steel	YTP02IU
For weighing platforms in electropolished material or made entirely of stainless steel AISI 316 Ti stainless steel	
For attaching the weighing platform to the floor Floor-mounting set	YFP011

## Options

Columns can be manufactured to order on request.

Surface finishing:

- Electropolished surface
- AISI 316Ti stainless steel

## Dimensions

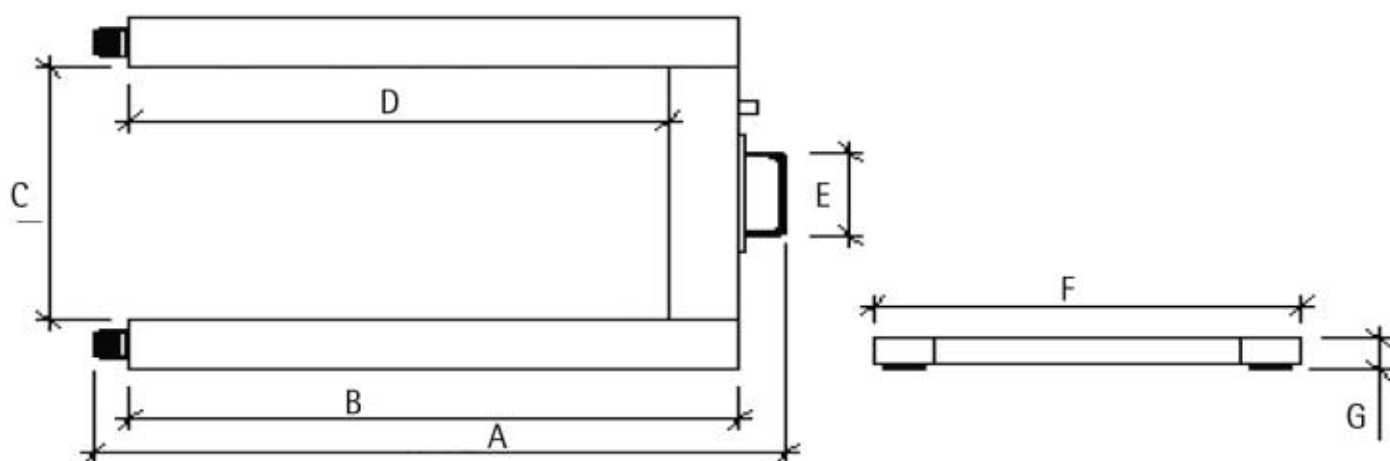

**Table**

All dimensions given in millimeters

A	B	C	D	E	F	G
1370	1190	600	1080	200	840	76

# Installation Instructions

## Unpacking the Equipment

- Please read the enclosed operating instructions carefully before putting the equipment into operation.

- After unpacking the equipment, please check it immediately for any visible damage.

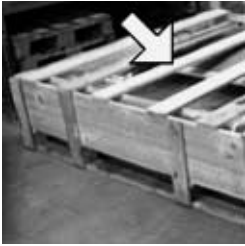

- Open the wooden pallet at the top.
- Lift the scale until it is completely free of the wooden pallet (see below).

### Note:

The height of the load-bearing feet can be adjusted. The scale is adjusted at the factory for a level floor. Improper handling of the scale can result in damage to the components, which negatively affects the safety of the device. Make sure to read and follow the safety instructions.

- Fasten the straps in four places, as shown here:



- Front: handles

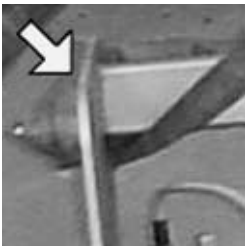

- Rear: carrier frame.

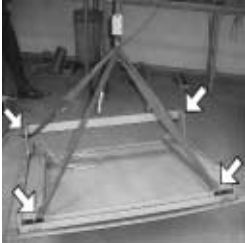

- Lift the scale evenly.
- Move the scale to the place of installation.

- ⚠ Warning: Danger of personal injury! Do not stand or move beneath the scale while it is suspended. Make sure to read and follow the safety instructions.



- Lower the scale evenly to the place of installation.
- The place of installation must be clean, level and able to withstand the weight of the scale and any load that will be placed on it. Eliminate any unevenness of the floor surface.

- Level the scale at the place of installation using the level indicator. Check the angularity of the base frame and make sure it is correct. Measure the diagonals to check this dimension.

- Mark the positions for drilling anchor holes.

- 8 fastening anchors, sizes M10 to M15 (length: 85 mm), are included in delivery

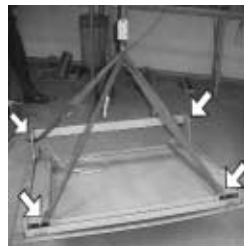

- Clear the place of installation. Lift the scale evenly.
- ⚠ Warning: Danger of personal injury! Do not stand or move beneath the scale while it is suspended. Make sure to read and follow the safety instructions.

- Drill the holes (size: M10) for the anchors. Minimum depth: 65 mm.

- Check the depth; remove all dust from the bore hole (use a blower if necessary).

- Clean the place of installation.

- Carefully re-position the scale at the place of installation. Make sure to align the holes drilled for the anchors with the bore holes on the base frame.



- Level the scale at the place of installation using the level indicator. Check the angularity of the base frame and make sure it is correct. Measure the diagonals to check this dimension.

- Fasten the scale as follows: Drive in the anchors and tighten the bolts (size M10; wrench size: 17).

- Check the gap between the down-holders (right and left) and the scale; it should be 2 mm.
  - Use a 2-mm thick spacing plate or
  - Measure the gap.



- Check this gap at regular intervals to make sure the 2-mm space is maintained.



- Adjust the gap as needed. If necessary, loosen the bolts that attach the downholder. Bolt size: M8; wrench size: 13.



- Before the scale platform can be raised to a vertical position, loosen the stop bolts on the right and left.
- ⚠ Danger of damage to the stop bolts! The rear stop bolts must be disengaged!

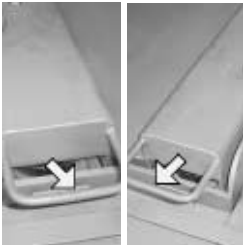

- Grasp the platform by the handles and raise it to the vertical position.
- Note: Two persons are required for raising the platform.
- ⚠ Please observe the safety instructions, as there is a hazard of personal injury. Always wear safety gloves while raising or lowering the platform.



- ⚠ Warning: Danger of personal injury! Do not stand or move beneath the platform.



- Turn the left and right stop bolts. The bolts slide into the side plate and secure the platform in the vertical position.
- The surface under the platform can now be cleaned easily.



- Install the pneumatic springs (right and left) as shown in the illustration. Tighten the bolts (size M10; wrench size: 17).

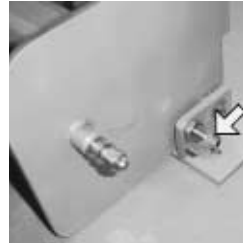

- Following installation, return the platform to the horizontal position.
- Turn the rear stop bolts (right and left). The bolts slide out of the side plate and release the platform.
- ⚠ Danger of damage to the stop bolts! The stop bolts must be disengaged!



- Grasp the platform by the handles and lower it to the horizontal position.
- Note: Two persons are required for lowering the platform!
- ⚠ Please observe the safety instructions, as there is a hazard of personal injury. Always wear safety gloves while raising or lowering the platform. Do not stand or move beneath the platform.

- The platform is now in the horizontal position.
- Place your foot on the right-hand downholder to press the side plate of the scale to the floor; repeat this procedure on the left-hand side as well.

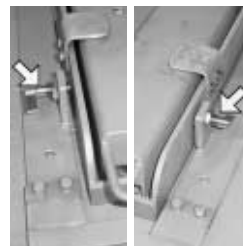

- Position the front stop bolts (right and left) to fix the scale in position and turn the lever.



- Remove the right and left mounting aids as follows: Unscrew the four M8 bolts as shown (wrench size: 13).



- Hook the drive-on ramp onto the right and left retainers.

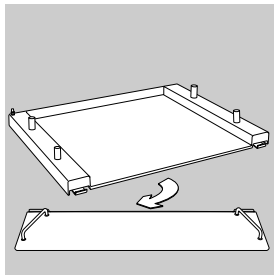

### Transporting the IFXS4... (Option T7)

- Remove the drive-on ramp from the front of the scale.
- Make sure there is no load on the scale.
- Make sure to observe the safety instructions.

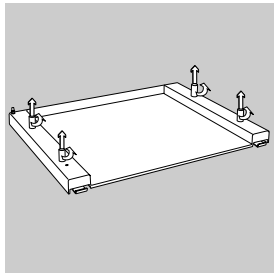

- Remove the threaded caps from the four threaded fasteners and save them in a safe place.
- Lubricate the threaded fasteners regularly, so that the caps can be removed and the hand cranks attached at any time without difficulty.

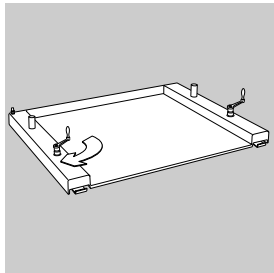

- Attach the two hand cranks to the two threaded fasteners at the front of the scale.
  - Turn the cranks clockwise to lower the transport rollers.
  - Repeat this procedure for the two rear rollers.
- Important:**  
Make sure there is no load on the platform before you move it.

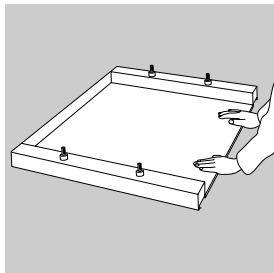

- The scale can now be pushed into the desired position (rate of speed: < 1m/s). Please observe the safety instructions.

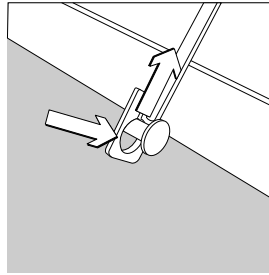

- If available, fasten the towing bar (optional) as shown.

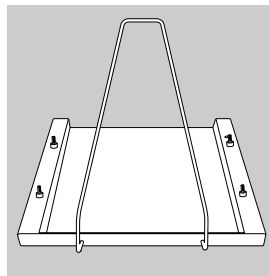

- The scale can now be pulled into the desired position (rate of speed: < 1 m/s). Please observe the safety instructions.
- This procedure is useful, for example, for cleaning the surface beneath the scale at the place of installation.

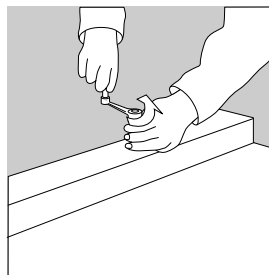

- Return the weighing platform to the place of installation and retract the rollers.

- Remove the hand crank.
- Replace the four threaded caps.

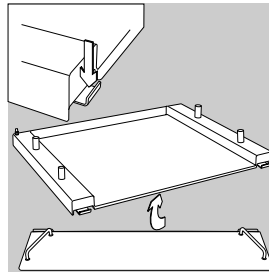

- Fasten the drive-on ramp to the front of the scale.
- Make sure to observe the safety instructions.

## Connecting the IUXS... or IFXS...

### Connecting Cable: IUXS.. or IFXS.. to Indicator

		No.: EX	Cable: type A	or	Cable: type B
V +	(Supply voltage +)	1	(white)	or	blue
V -	(Supply voltage -)	3	(brown)	or	black
Signal +	(Output signal +)	5	(green)	or	white
Signal -	(Output signal -)	6	(yellow)	or	red
Sense +	(Shield +)	2	(pink)	or	green
Sense -	(Shield -)	4	(gray)	or	gray
Ground	(Shield)				

# Installation of the Indicator

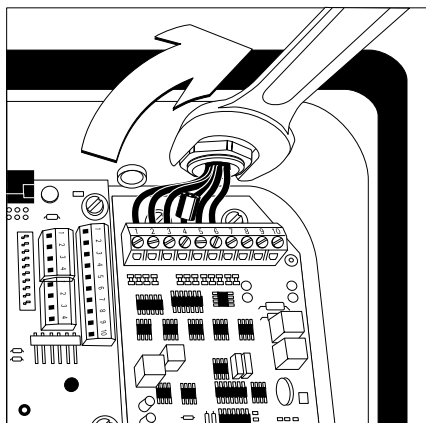

- Connect the cable of the weighing platform to a suitable indicator, such as the CIXS3-U or FCT01-X from Sartorius.

**Note:**

The cable gland along with the screw fasteners is already pre-assembled. Use extreme care when attaching or detaching a cable.

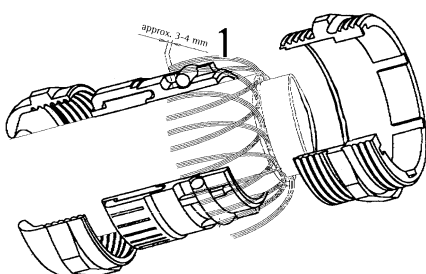

- Strip off the insulation at the cable end and attach the cable as follows:
  - Route the cable through the cable gland.
  - Properly tighten the screw fasteners of the cable gland
  - Remove the sheathing from a section of the cable end (see illustration). The shield (1) must have contact with the clamps (2).
  - Expose approximately 15 cm (6 inches) of the wires (3) for installation.

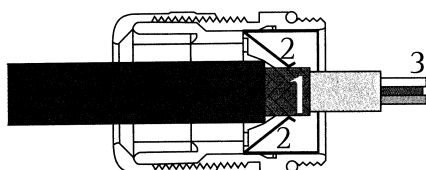

- Attach the cable to the weighing platform as follows:
  - Expose approximately 5 cm (2 inches) of the wires for installation.
  - Expose approximately 1 cm (1/2 inch) of the wires and attach ferrules to the wires.
  - Securely attach the wires to the screw terminals

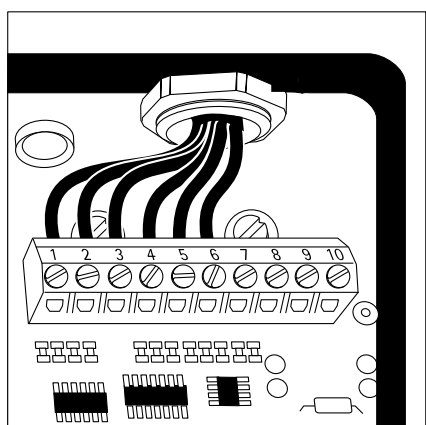

### Wiring Diagram for the Indicator

No.	Signal name	Meaning	Conductor coloring
1	BR_POS	Bridge supply voltage (+)	Blue
2	SENSE_POS	Sense (+)	Green
3	OUT_POS	Bridge supply voltage	White
4	OUT_NEG	Measuring voltage (-)	Red
5	SENSE_NEG	Sense (-)	Gray
6	BR_NEG	Bridge supply voltage (-)	Black or brown

- Use a screwdriver to tighten the terminal screws.

**Note on connecting the FCT01-X:**

The bridge supply voltages are protected by 62 mA fuses. To prevent the fuses from reacting if wires are incorrectly connected, resistors between pin 1 and pin 6, between pin 1 and the housing and between pin 6 and the housing must measure greater than 140 ohms. Low-ohm connections are also required between pin 1 and 2 and between pins 5 and 6.

# Care and Maintenance

## Service

Regular servicing by a Sartorius technician will extend the service life of your scale or weighing system and help to ensure its continued weighing accuracy. Sartorius can offer you service contracts, with your choice of regular maintenance intervals ranging from 1 month to 2 years.

## Repairs

- ⚠ Disconnect defective equipment from power immediately. Repairs may be performed only by authorized Sartorius service technicians using genuine Sartorius parts. Any attempt by untrained persons to perform repairs may result in considerable hazards for the user.
- ⚠ If a cable or cable gland is damaged or defective, replace the cable as a complete unit with all its connectors.

## Cleaning

- ⚠ Always handle the equipment in keeping with its IP protection rating. Make sure that no liquid enters the IP.. housing.
- Unplug the system from power before cleaning or performing maintenance or repair work. Clean the system regularly to remove all impurities.
- Avoid generating static electricity. Devices rated to IP65 can be rinsed down with a jet of water that strikes the load plate from above.
- ⚠ When using high-pressure cleaning equipment to clean the scale, do not point the jet of steam directly at the load cells.
- > If the water that you use to clean the scale is too hot or too cold, the difference in temperature between the water and the scale can cause condensation inside the scale housing. This condensation can lead to malfunctions in the equipment.

## Cleaning Beneath the Load Plate (Option T8)

Important Note:

The load plate must be locked into the vertical position or held in this position by a second person.

Warning: Danger of personal injury! Make sure to observe all warnings and the safety precautions. All personnel must wear steel-toed boots while performing work that involves lifting or raising the load plate.

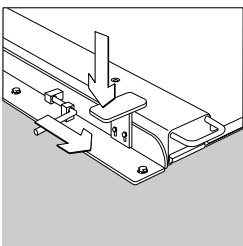

- Use the foot switches on the right and left and lower the safety catch.

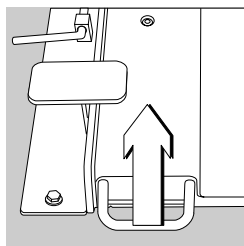

- Use the handle to lift the front of the load plate upwards. Observe all warnings and safety precautions! Important: Lock the load plate into the vertical position.

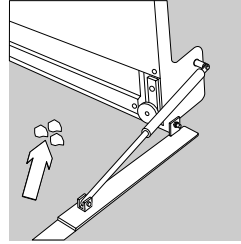

- Clean the area beneath the load plate.

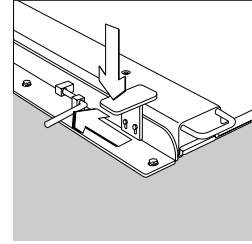

- Unlock the load plate from the vertical position, use the handle to lower the load plate, and secure the safety catches on the right and left.  
Important:  
If you do not unlock the load plate, the locking mechanism will be damaged.  
Make sure the warnings and safety precautions are observed.

## Cleaning Stainless Steel Surfaces

Clean all stainless steel parts regularly. Use a damp cloth or sponge to clean any stainless steel parts on the system. You can use any commercially available household cleaning agent that is suitable for use on stainless steel. Clean stainless steel surfaces by wiping them down. Then rinse the equipment thoroughly, making sure to remove all residues. Wipe down stainless steel parts again using a clean, damp cloth or sponge. Afterwards, allow the equipment to dry. If desired, you can apply oil to the cleaned surfaces as additional protection.

- ⚠ Do not use stainless steel cleaning agents that contain soda lye (caustic), acetic acid, hydrochloric acid, sulfuric acid or citric acid. The use of scrubbing sponges made with steel wool is not permitted. Solvents are permitted only for cleaning stainless steel parts.

## Corrosive Environment

- Remove all traces of corrosive substances on a regular basis.

## Safety Inspection

If there is any indication that safe operation is no longer warranted; i.e.:

- If there is visible damage to the connecting cable,
- If the device no longer functions properly,
- If the equipment has been stored for a relatively long period under unfavorable conditions, or
- If the equipment has been subjected to rough handling during shipment,
- Make sure all safety instructions are observed, and notify your nearest Sartorius Service Center or the International Technical Support Unit based in Goettingen, Germany. Maintenance and repair work may be performed only by authorized Sartorius service technicians who have access to the required maintenance manuals and have received the necessary training.
- ⚠ The seals affixed to this equipment indicate that only authorized service technicians are allowed to open the equipment and perform maintenance work so that safe and trouble-free operation of the equipment is ensured and the warranty remains in effect.

## Storage and Shipping Conditions

- The packaging used for shipping your Sartorius equipment is optimally designed to prevent damage during transport. It is a good idea to save the box and all parts of the packaging for future storage or shipment of the equipment. Only the original packaging provides the best protection for shipment.
- Allowable storage temperature: -20°C to +75°C (-4°F to +167°F)
- Allowable humidity during storage: max. 90%
- Please refer to the information under "Warnings and Safety Precautions."





FM Approvals  
 1151 Boston-Providence Turnpike  
 P.O. Box 9102 Norwood, MA 02062 USA  
 T: 781 762 4300 F: 781 762 9375 www.fmaprovals.com

Member of the FM Global Group

# CERTIFICATE OF COMPLIANCE

## HAZARDOUS LOCATION ELECTRICAL EQUIPMENT

This certificate is issued for the following equipment:

**CIXS3- and CW3X..U-.....-..... Indicators and Complete Scales**

IS/I,II,III/1,2/ABCDEFGF - 65607-000-07-A4 T4; Entity see control drawing  
 I,II/1,20/ AEx ib IIC T4 - 65607-000-07-A4 T4; Entity see control drawing  
 AEx ia/I,II,III/1,2/ABCDEFGF - 65607-000-07-A4 T4; Entity see control drawing  
 1,20 AEx ib IIC T4 - 65607-000-07-A4 T4; Entity see control drawing

**CAPX..U-.....-.....IUX.4-.....-..... and IFX.4-.....-..... Platforms**

IS/I,II,III/1,2/ABCDEFGF -35739-003-07-A4 or 65607-000-07-A4 T4 at Ta\*; Entity  
 I,II/1,20 AEx ib IIC T4- 35739-003-07-A4 or 65607-000-07  
 AEx ia/I,II,III/1,2/ABCDEFGF -35739-003-07-A4 or 65607-000-07-A4 T4 at Ta\*; Entity  
 1,20 Ex ib IIC T4 - 35739-003-07-A4 or 65607-000-07

\*see table

Vmax	I <sub>max</sub>	Pi	Ci (cable)	Li (cable)	Ta
17 Vdc	410 mA	1.25W	162 pF/m	0,6µH/m	60°C
13 Vdc	410 mA	2.00W	162 pF/m	0,6µH/m	40°C

**YDI05-Z Interface Converter**

AIS/I,II,III/1,2/ABCDEFGF - 65710-800-07-A4; Entity  
 I,II/1,20/ [AEx ib] IIB/IIC -65710-800-07-A4; Entity  
 [AEx ia]/AIS/I,II,III/1,2/ABCDEFGF - 65710-800-07-A4; Entity  
 1,20 [AEx ib] IIB/IIC - 65710-800-07-A4; Entity

Equipment Ratings:



Intrinsically safe circuits or connections for Class I, II, III Division 1, Groups A, B, C, D, E, F and G T4, Class I, Zone 1, AEx ib IIC T4, Class II, Zone 20 per control drawing 65607-000-07-A4; hazardous (classified) locations and will appear in the Approval Guide, a publication of FM Approvals, as follows:

**FM Approved for:**

SARTORIUS AG  
WEENDER LANDSTRASSE 94-108  
D-37070 GÖTTINGEN  
GERMANY



This certifies that the equipment described has been found to comply with the following Approval Standards and other documents:

Class 3600	1998
Class 3810	2005
Class 3610	1999
ANSI/ISA-12.16.01	2002
ANSI/ISA -12.23.01	2002
Class 3611	1999

Original Project ID: 3023378

Approval Granted: 3/10/06

Subsequent Revision Reports / Date Approval Amended

Report Number	Date	Report Number	Date
---------------	------	---------------	------

FM Approvals LLC

  
\_\_\_\_\_  
George A. Smith  
Assistant Vice President

3/10/06  
\_\_\_\_\_  
Date



Member of the FM Global Group

FM Approvals  
 1151 Boston-Providence Turnpike  
 P.O. Box 9102 Norwood, MA 02062 USA  
 T: 781 762 4300 F: 781 762 9375 www.fmaprovals.com

# CERTIFICATE OF COMPLIANCE

## HAZARDOUS LOCATION ELECTRICAL EQUIPMENT PER CANADIAN REQUIREMENTS

This certificate is issued for the following equipment:

**YRB02-X Ex RECHARGEABLE BATTERY PACK**

AIS/I,II,III/1,2/ABCDEFGF – 65656-000-07-A4  
 I/1/ Ex e m [ib] IIC –35960-000-07-A4  
 I,II,III/2/ABCDEFGF T4  
 Zone 20

**YDI05-Z Interface Converter**

AIS/I,II,III/1,2/ABCDEFGF – 65710-800-07-A4; Entity  
 I,II/1,20/ [Ex ib] IIB/IIC –65710-800-07-A4; Entity  
 [Ex ia]/AIS/I,II,III/1,2/ABCDEFGF – 65710-800-07-A4; Entity  
 1,20 [Ex ib] IIB/IIC – 65710-800-07-A4; Entity

**CAPX..U.....-.....IUX.4.....-..... and IFX.4.....-..... Platforms**

IS/I,II,III/1,2/ABCDEFGF -35739-003-07-A4 or 65607-000-07-A4 T4 at Ta\*; Entity  
 I,II/1,20 Ex ib IIC T4- 35739-003-07-A4 or 65607-000-07  
 Ex ia/I,II,III/1,2/ABCDEFGF -35739-003-07-A4 or 65607-000-07-A4 T4 at Ta\*; Entity  
 1,20 Ex ib IIC T4 - 35739-003-07-A4 or 65607-000-07

\*see table

Vmax	I <sub>max</sub>	P <sub>i</sub>	C <sub>i</sub> (cable)	L <sub>i</sub> (cable)	T <sub>a</sub>
17 Vdc	410 mA	1.25W	162 pF/m	0,6µH/m	60°C
13 Vdc	410 mA	2.00W	162 pF/m	0,6µH/m	40°C

**CIXS3-. and CW3X..U.....-..... Indicators and Complete Scales**

IS/I,II,III/1,2/ABCDEFGF – 65607-003-07-A4 T4; Entity see control drawing  
 I,II/1,20/ Ex ib IIC T4 – 65607-000-07-A4 T4; Entity see control drawing  
 Ex ia/I,II,III/1,2/ABCDEFGF - 65607-000-07-A4 T4; Entity see control drawing  
 1,20 Ex ib IIC T4 - 65607-000-07-A4 T4; Entity see control drawing



**Equipment Ratings:**

Intrinsically safe circuits or connections for Class I, II, III Division 1, Groups A, B, C, D, E, F and G T4, Class I, Zone 1, Ex ib IIC T4, Class II, Zone 20 per control drawing 65607-000-07-A4; hazardous (classified) locations and will appear in the Approval Guide, a publication of FM Approvals, as follows:

**FM Approved for:**

SARTORIUS AG  
WEENDER LANDSTRASSE 94-108  
D-37070 GÖTTINGEN  
GERMANY



This certifies that the equipment described has been found to comply with the following Approval Standards and other documents:

CSA C22.2 No. 142	1987
C22.2 No. 157-92	1992
ANSI/ISA-12.16.01	2002
ANSI/ISA -12.23.01	2002

Original Project ID: 3023378C

Approval Granted: 3/10/06

Subsequent Revision Reports / Date Approval Amended

Report Number	Date	Report Number	Date
---------------	------	---------------	------

FM Approvals LLC

George A. Smith  
Assistant Vice President

3/10/06  
Date

**Hazardous (Classified) Location**  
**Class I,II,III, Division 1, Groups A,B,C,D,E,F,G T4**  
**Class I, Zone 1, Groups IIA, IIB, IIC T4**  
**Class II, Zone 20**

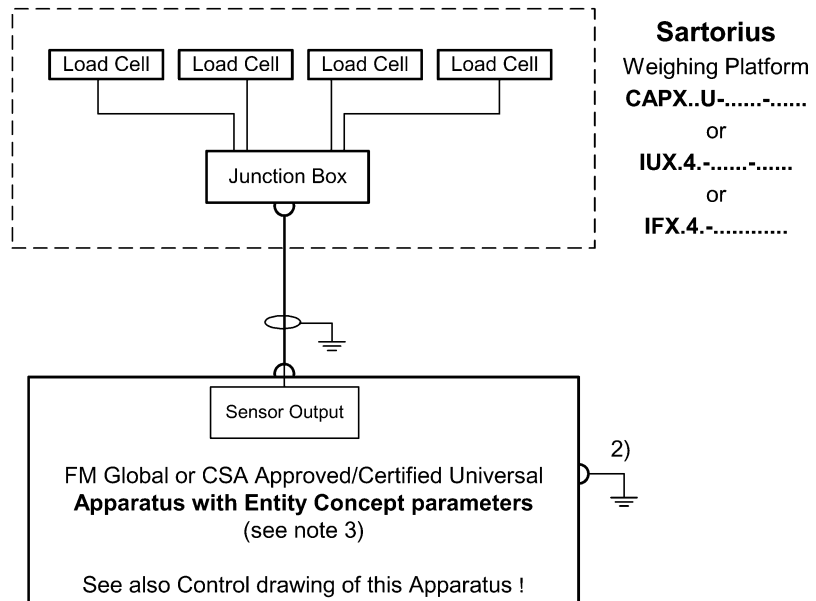

**Parameters** of the weighing platform:

Ui	Ii	Pi	Ci	Li	Ta
17 V	410 mA	1,25 W	162 pF/m 49 pf/ft	0,6 μH/m 0,18μH/ft	+60°C / +140°F
13 V	410 mA	2,00 W	162 pF/m 49 pf/ft	0,6 μH/m 0,18μH/ft	+40°C / +104°F

- 1) In the **USA**: The installation must be in accordance with the National Electrical Code ®, NFPA 70, Article 504 or 505 and ANSI / ISA-RP 12.6.  
 In **Canada**: The installation must be in accordance with the Canadian Electrical Code ®, Part1, Section 18.
- 2) In the **USA**: The Apparatus must be connected to a suitable ground electrode per National Electrical Code ®, NFPA 70, Article 504 or 505. The resistance of the ground pad must be less than 1 ohm.  
 In **Canada**: The Apparatus must be connected to a suitable ground electrode per Canadian Electrical Code ®, Part 1. The resistance of the ground pad must be less than 1 ohm.
- 3) The Entity Concept allows interconnection of intrinsically safe apparatus with associated apparatus not specifically examined in combination as a system when the approved values of Voc, Isc and Pmax resp. Uo, Io, Po of the associated apparatus are less than or equal to Vmax, Imax and Pmax resp. Ui, Ii, Pi of the intrinsically safe apparatus and the approved values of Ca and La resp. Co and Lo of the associated apparatus are greater than Ci and Li of the intrinsically safe apparatus plus all cable parameters.
- 4) Ambient temperature range: -20°C .... +40°C or +60°C (-4°F .... + 104°F or +140°F)  
 Maximum ambient temperature for IUX.4.-.....-....., IFX.4.-.....-..... : +40°C (+ 104°F)
- 5) **WARNING**: SUBSTITUTION OF COMPONENTS MAY IMPAIR INTRINSIC SAFETY.

			Title		sartorius	
Written by	2005-11-11	Klausgrete		<b>Control Drawing</b>	<b>Revision</b> 00	Page 1 of 2
Reviewed by	2005-11-11	Klausgrete		Drawing number <b>35739-003-07-A4</b>		
Released by	2005-11-11	Klausgrete				

**Hazardous (Classified) Location**  
**Class I,II,III, Division 2, Groups A,B,C,D,E,F,G T4**  
**Class I, Zone 2, Groups IIA, IIB, IIC T4**  
**Class II, Zone 22**

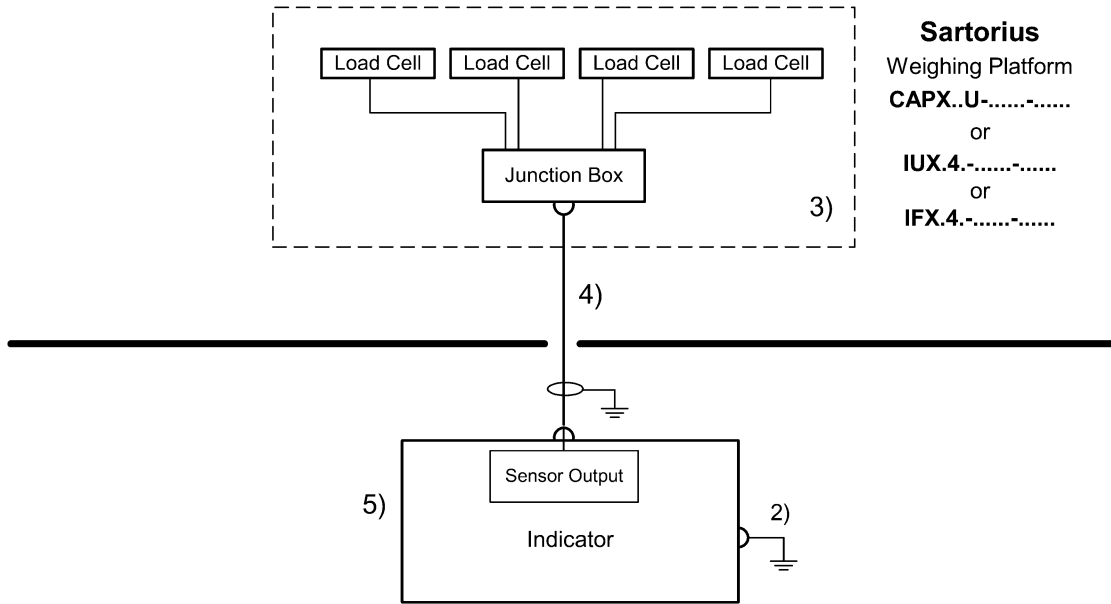

**Sartorius**  
Weighing Platform  
**CAPX..U-.....-.....**  
or  
**IUX.4-.....-.....**  
or  
**IFX.4-.....-.....**

- 1) In the **USA**: The installation must be in accordance with the National Electrical Code ®, NFPA 70, Article 504 or 505 and ANSI / ISA-RP 12.6.  
In **Canada**: The installation must be in accordance with the Canadian Electrical Code ®, Part1, Section 18.
- 2) In the **USA**: The Apparatus must be connected to a suitable ground electrode per National Electrical Code ®, NFPA 70, Article 504 or 505. The resistance of the ground pad must be less than 1 ohm.  
In **Canada**: The Apparatus must be connected to a suitable ground electrode per Canadian Electrical Code ®, Part 1. The resistance of the ground pad must be less than 1 ohm.
- 3) Ambient temperature range for the weighing platform: -20°C .... +60°C (-4°F .... + 104°F or +140°F)
- 4) The cable from the indicator to the weighing platform must be a NRTL approved/certified (flexible) conduit or the cable is connected to the output of the indicator via NRTL approved/certified barriers (limitation to maximum voltage of 17V) or the indicator is NRTL approved/certified for Division 2.
- 5) The indicator must be installed outside hazardous locations or must be approved/certified by an NRTL for use in hazardous locations.
- 6) **WARNING**: SUBSTITUTION OF COMPONENTS MAY IMPAIR INTRINSIC SAFETY.

	Date	Name	Title		Revision		
Written by	2005-11-11	Klausgrete		<b>Control Drawing</b>			
Reviewed by	2005-11-11	Klausgrete		Drawing number	<b>35739-003-07-A4</b>	<b>00</b>	Page 2 of 2
Released by	2005-11-11	Klausgrete					



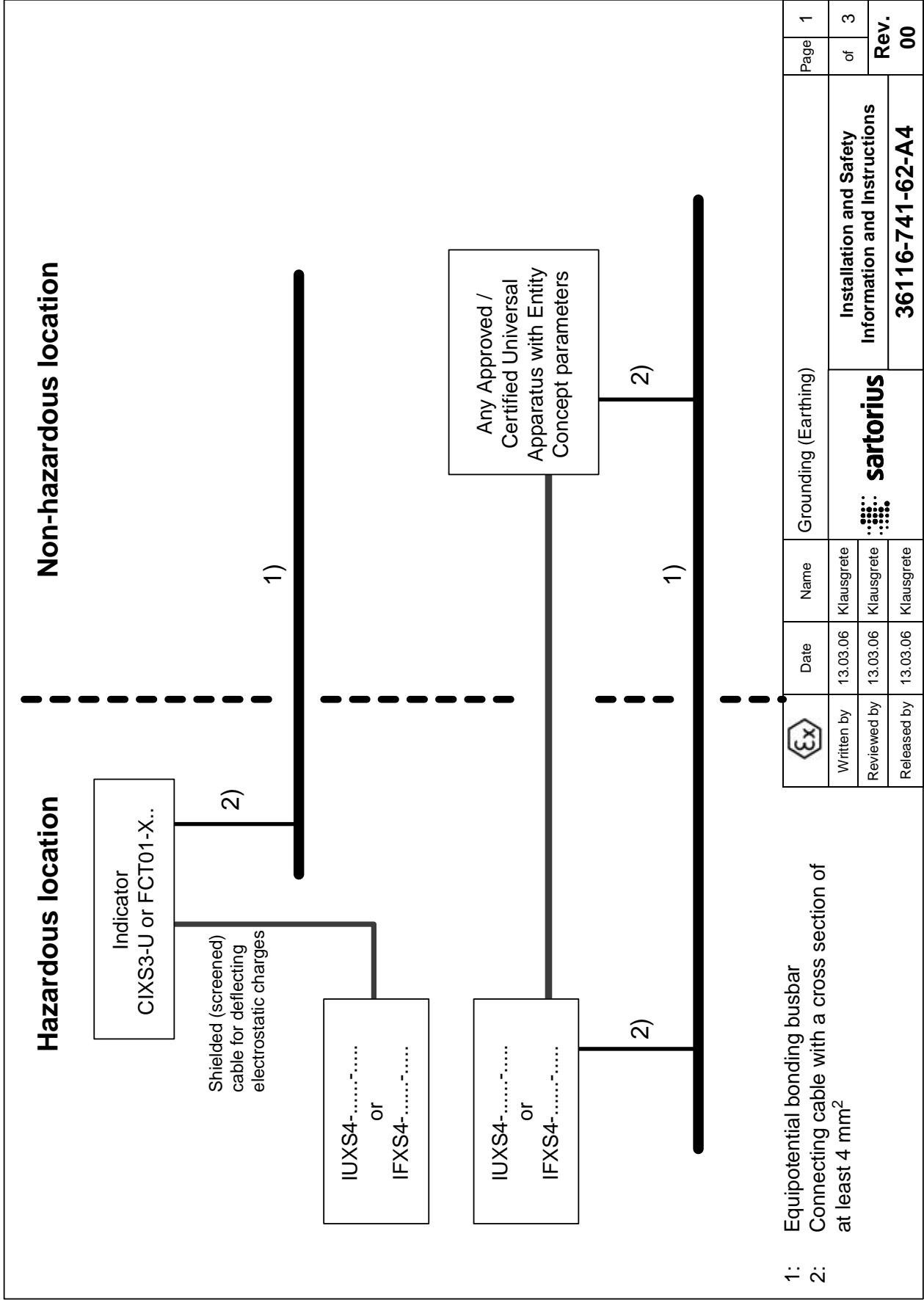

### Hazardous location

### Non-hazardous location

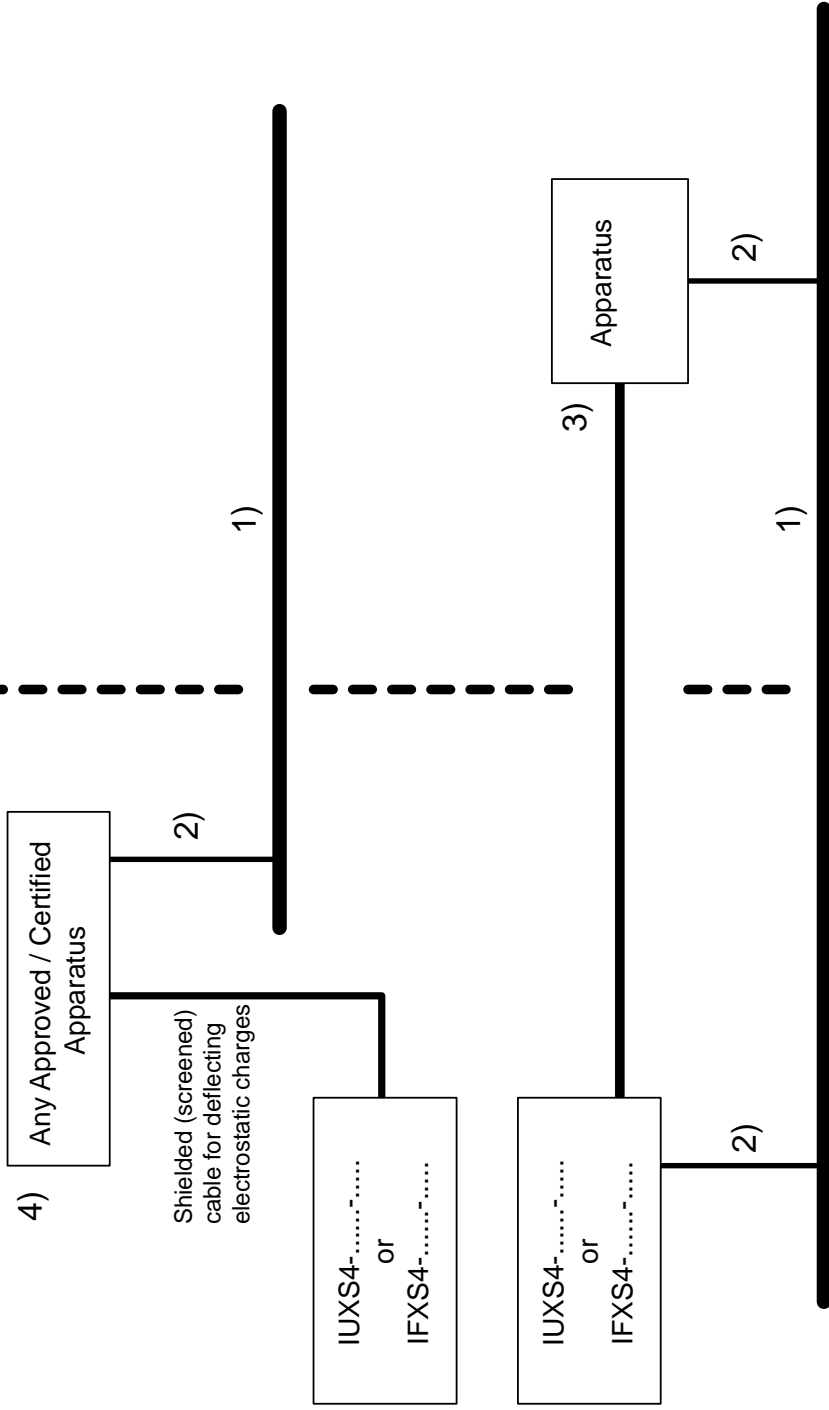

- 1: Equipotential bonding busbar
- 2: Connecting cable with a cross section of at least 4 mm<sup>2</sup>
- 3: see note 4) and 5) on page 2 of Control Drawing 35739-003-07-A4 e.g. **PR1713** and **PR5610** ;
- 4: only for use in the USA (NI/II/2/ABCD/T5)

	Date	Name	Grounding (Earthing)		Page	2
	Written by	Klausgrete		<b>Installation and Safety Information and Instructions</b>	of	3
	Reviewed by	Klausgrete			Rev.	<b>00</b>
Released by	Klausgrete	<b>36116-741-62-A4</b>				

## Hazardous location

**Avoid generating static electricity :**  
 Pull the weighing platform slowly  
 (rate of your steps < 1 m/s)  
 or connect a grounding cable

Plastic rollers  
 (included in standard  
 equipment supplied)

Option:  
 Grounding (earthing) cable  
 suitable for hazardous locations;  
 non-sparking; not included in  
 standard equipment supplied

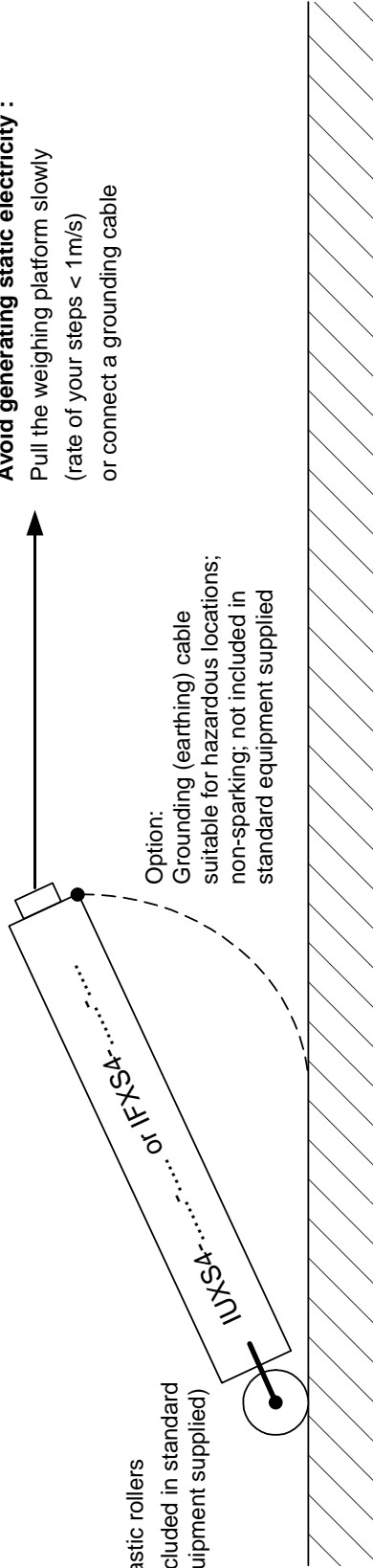

**Avoid generating static electricity :**  
 Pull the weighing platform slowly  
 (rate of your steps < 1 m/s)  
 or connect a grounding cable

Lifting mechanism:  
 Rollers can be extended

Option:  
 Grounding (earthing) cable  
 suitable for hazardous locations;  
 non-sparking; not included in  
 standard equipment supplied

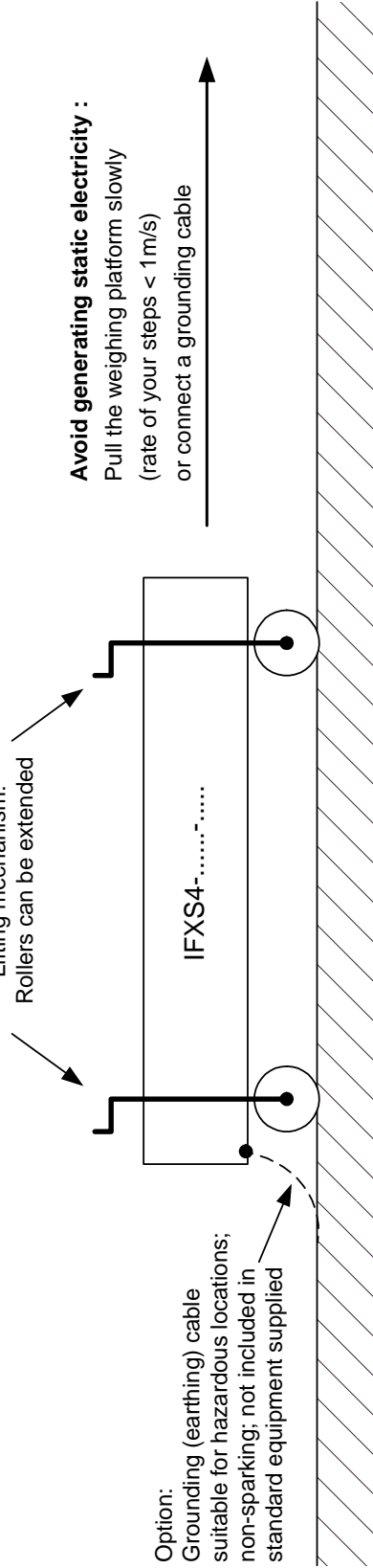

	Written by	13.03.06	Name	Rollers for LUXS4-..... or IFXS4-.....		Page	3
	Reviewed by	13.03.06			Installation and Safety Information and Instructions	of	3
	Released by	13.03.06				Rev.	00
					36116-741-62-A4		

Plastic rollers  
 (included in standard  
 equipment supplied)

Sartorius AG  
Weender Landstrasse 94–108  
37075 Goettingen, Germany

Phone +49.551.308.0  
Fax +49.551.308.3289  
www.sartorius.com

Copyright by Sartorius AG,  
Goettingen, Germany.  
All rights reserved. No part  
of this publication may  
be reprinted or translated in  
any form or by any means  
without the prior written  
permission of Sartorius AG.  
The status of the information,  
specifications and illustrations  
in this manual is indicated  
by the date given below.  
Sartorius AG reserves the  
right to make changes to  
the technology, features,  
specifications and design of  
the equipment without notice.

Status:  
March 2006, Sartorius AG,  
Goettingen, Germany