



**Waist-High
Stand-On Scale
Models 6855, 6855KGEU
6856 & 6856KGEU
Operating Instructions**

WAIST-HIGH STAND-ON SCALE

Thank you for purchasing our model 6855 (6855KGEU) or 6856 (6856KGEU) Waist-High Stand-On Scale. It has been manufactured with quality and reliability at our factory in Webb City, MO USA. Your scale has been tested before leaving our factory to insure accuracy and dependability for years to come.

This manual is provided to guide you through the operation of your scale. Please read it thoroughly before attempting to operate your scale and keep it handy for future reference.

FCC COMPLIANCE STATEMENT

WARNING! This equipment generates, uses and can radiate radio frequency and if not installed and used in accordance with the instruction manual, may cause interference to radio communications. It has been tested and found to comply with the limits for a Class A computing device pursuant to Subpart J of Part 15 of FCC rules, which are designed to provide reasonable protection against such interference when operated in a commercial environment. Operation of this equipment in a residential area may cause interference in which case the user will be responsible to take whatever measures necessary to correct the interference.

You may find the booklet "How to Identify and Resolve Radio TV Interference Problems" prepared by the Federal Communications Commission helpful. It is available from the U.S. Government Printing Office, Washington, D.C. 20402. Stock No. 001-000-00315-4.

All rights reserved. Reproduction or use, without expressed written permission, of editorial or pictorial content, in any manner, is prohibited. No patent liability is assumed with respect to the use of the information contained herein. While every precaution has been taken in the preparation of this manual, the Seller assumes no responsibility for errors or omissions. Neither is any liability assumed for damages resulting from use of the information contained herein. All instructions and diagrams have been checked for accuracy and ease of application; however, success and safety in working with tools depend to a great extent upon the individual accuracy, skill and caution. For this reason the Seller is not able to guarantee the result of any procedure contained herein. Nor can they assume responsibility for any damage to property or injury to persons occasioned from the procedures. Persons engaging the procedures do so entirely at their own risk.

SPECIFICATIONS

	6855	6855KGEU	6856	6856KGEU
Capacity	600 lb x .2 lb or 270 kg x .1 kg (selectable)	270 kg x .1 kg	800 lb x .2 lb or 360 kg x .1 kg (selectable)	360 kg x .1 kg
Platform Size	18" x 14" / 457 mm x 356 mm		24" x 24" / 610 mm x 610 mm	
Shipping Weight	70 lb / 32 kg		85 lb / 39 kg	
Scale Height	41.69 / 1059 mm			
Display	0.7" / 17.8 mm high-contrast LCD			
Power	6 "C" size Alkaline batteries (not included) or optional AC adapter			
Keys	On/Off, Zero, Lb/Kg, Hold/Release			
Features	Body Mass Index Calculator			

UNPACKING INSTRUCTIONS

- Remove staples or cut along bottom of carton. Lift carton off pallet.
- Check for any damage incurred in shipping. If scale has been damaged, place a claim with the carrier. *It is the responsibility of the purchaser to file all claims for any damages or loss incurred during transit.* Use the original carton and shipping material to return the scale.
- Cut packing straps securing scale to pallet.
- To remove scale from pallet, at the back of the scale lift up with equal force from the column and at the platform base near the wheels on the scale. Set gently on floor.
- Remove all plastic wrapping, foam fillers and cardboard material from the scale.
- Remove and unpack the power supply and cord, if the scale was ordered with this option.

CARE and CLEANING of SCALE

- DO NOT subject the platform to sudden shocks.
- DO NOT spray water directly on the display head.
- DO avoid areas where the scale might be exposed to moisture.
- DO NOT use abrasive cleaners on this instrument.
- DO NOT use acetone or other volatile solvents for cleaning.
- DO clean the scale using a damp soft cloth and mild detergent.

ERROR and STATUS DISPLAYS

Display	Meaning
-Err-	General error, invalid keypad entry was attempted.
-OF-	Attempting to display a negative number greater than -9,999 or a positive number greater than 99,999
-tRL-	Indicates an attempt to zero a weight outside the scale zero range. (See Four Percent Zero Tracking Range Limit).
-UnS-	Motion is present when the indicator is attempting to perform one of the following operations: Power Up Zero or Zero Weight Display
AdErr	An analog to digital convertor communication error has been detected. Consult the scale service representative.
[AL]b	Indicates improper stored calibration data, calibration is necessary.
ErrA	The analog to digital sample is invalid.
ErrAL	The load cell input is below the range of the indicator.
ErrAH	The load cell input is above the range of the indicator.
EE Err	NOVRAM failure. Consult the scale service representative.
OCAP	Scale weight exceeds scale capacity
OFF	Displayed to indicate the indicator is turning off.

OPERATING INSTRUCTIONS

1. Install six (6) "C" size Alkaline batteries or if ordered with the scale, plug the power supply module into an appropriate power receptacle. Plug the small connector end of the power supply cord into the power jack located in the bottom right corner at the back of the indicator.

NOTE! If you wish to operate the indicator from batteries, you must first obtain the batteries.

2. Set the scale on any hard, level, flat surface or low-cut carpet.
3. With no weight on the scale platform, press the [**ON/OFF**] key. After a second or so the display should indicate a zero weight with the ZERO annunciator turned on. If the display does not indicate zero, press the [**ZERO**] key to zero the weight display.
4. Step on the scale and remain motionless for several seconds until the scale displays your weight.
5. To re-zero the scale, remove all weight from the platform and press the [**ZERO**] key.
6. For more information, see the 758C Series Operation Manual (8555-M210-O1).

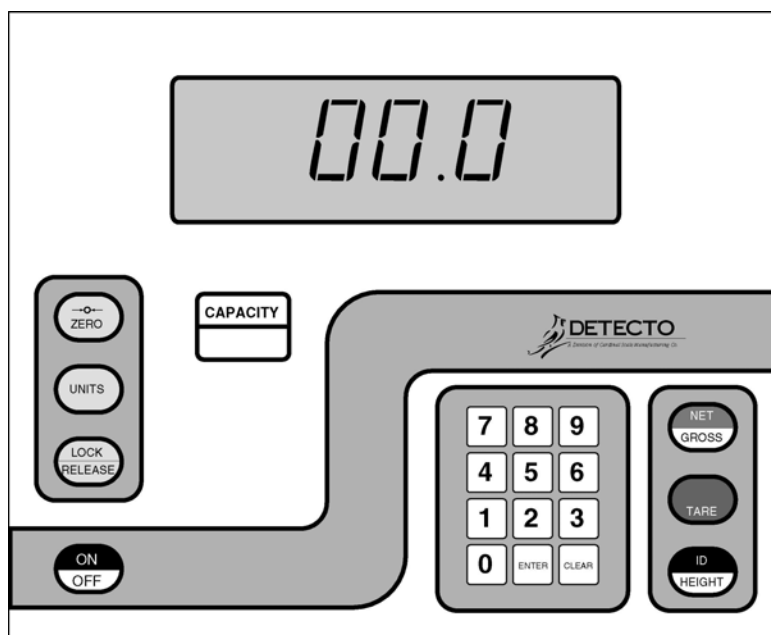
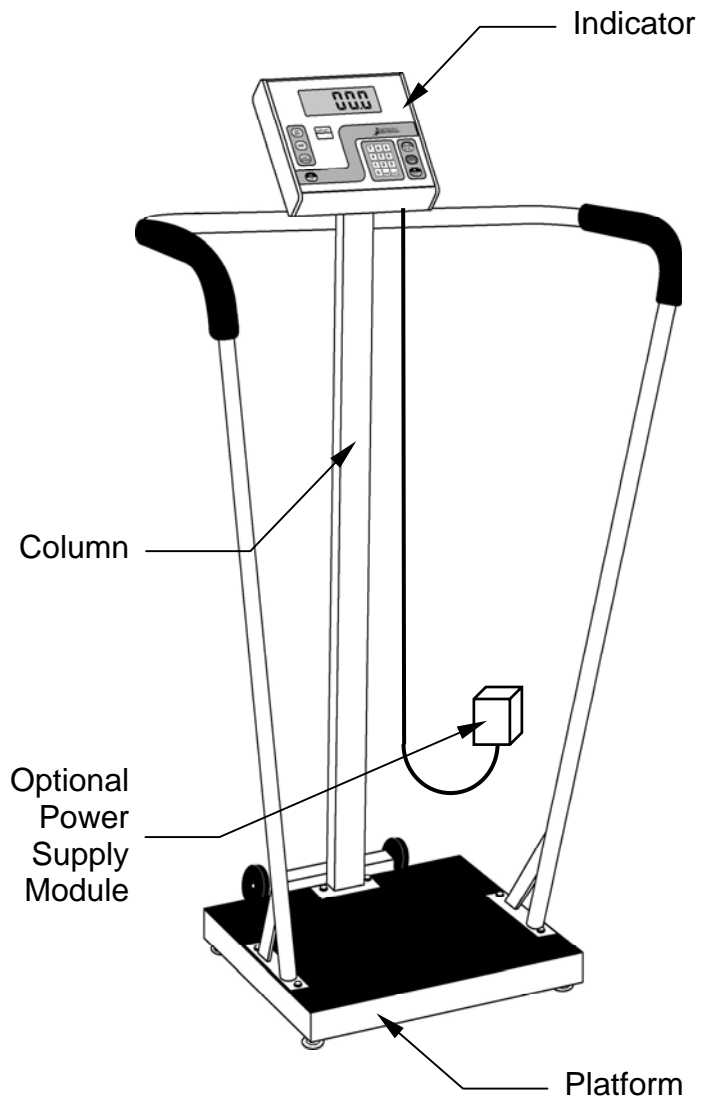

758C Keypad

Height Rod Instructions

Height Rod Hole Location

- Please check Height Rod hole locations before installing Height Rod.
- **Some models may require holes to be drilled.**
- Please follow the measurements for drilling holes if necessary.
- After holes have been drilled, please follow installation instructions.
- Install the two (2) #10 x ½" hex head screws from the hardware pack into the column.

IMPORTANT!
Measure from top of scale base.

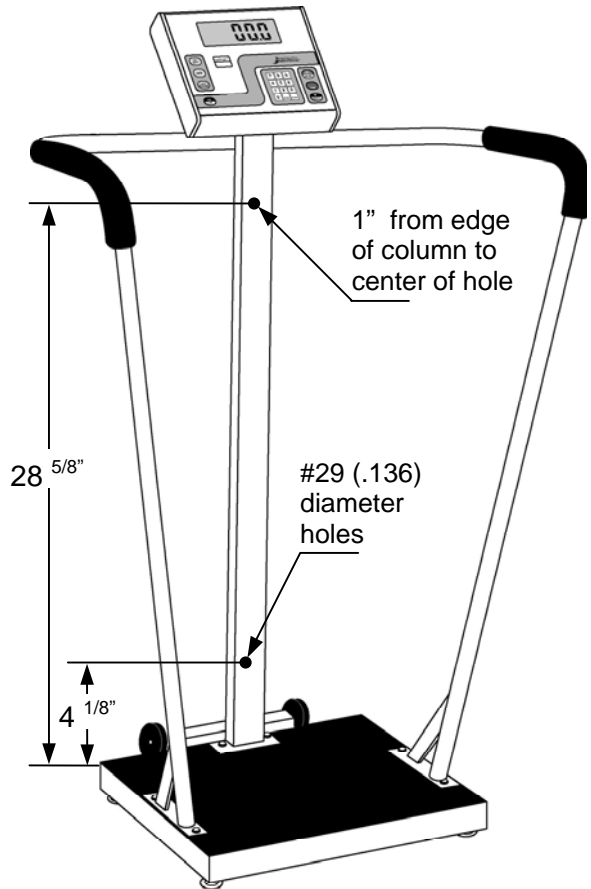

Height Rod Installation Instructions

1. Remove Height Rod from shipping container. Inspect the unit for signs of damage. Contact our Customer Service Department if necessary.
2. Loosen screws located on front of scale column. Place height rod brackets over screws and pull down; securing brackets. Tighten screws as needed.

NOTE! The Indicator must be facing away from the scale platform to install the height rod.

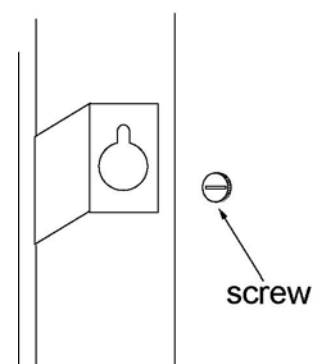

Height Rod Operation

1. Raise the inner rod of the telescoping column.
2. Lift up the spoon and lower the inner rod until the spoon rests on the patient's head.

CAUTION! Do not raise or lower Height Rod by spoon tip!

3. Read the correct height measurement on the inner rod at the top of the outer rod.

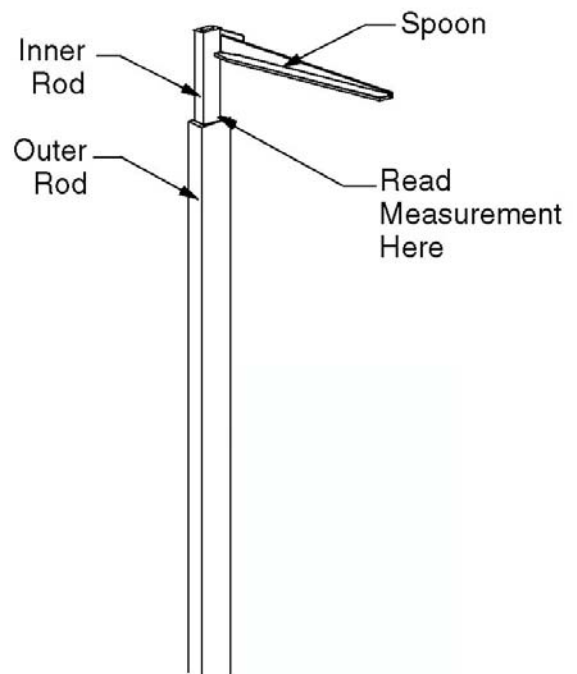

PART IDENTIFICATION

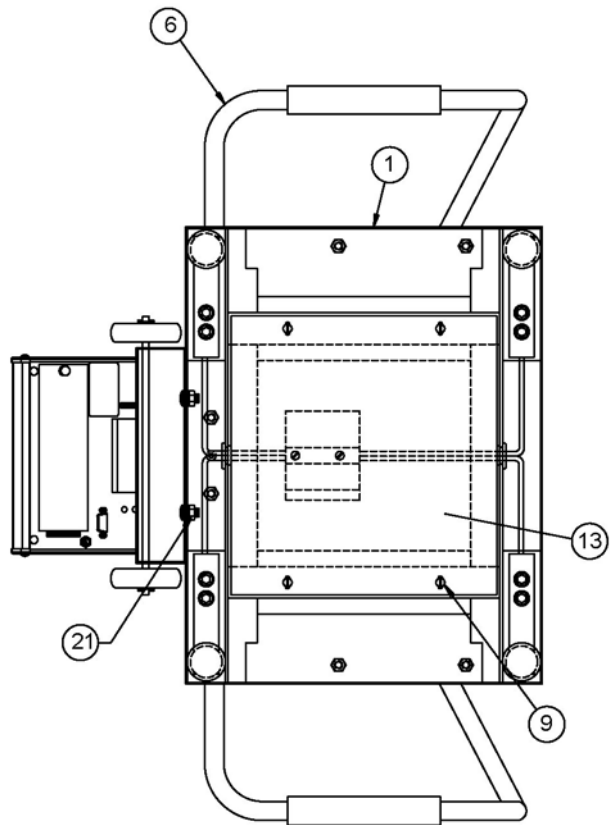
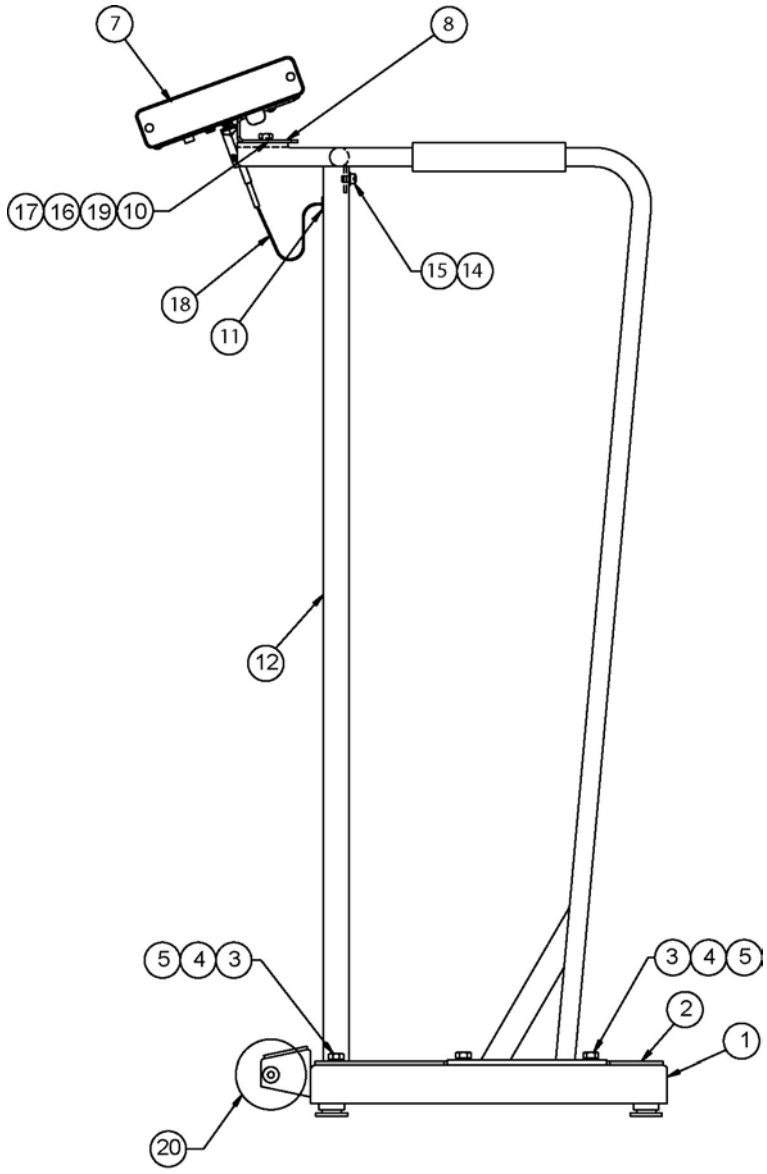

PART IDENTIFICATION

ITEM NO.	QTY 6855	QTY 6856	PART NUMBER	DESCRIPTION
1	1		1930-D330-0A	WEIGHBRIDGE ASSY
		1	1930-D445-0A	WEIGHBRIDGE ASSY (6856)
2	1		1930-C338-08	MAT W/ADHESIVE
		1	1930-C452-08	MAT W/ADHESIVE (6856)
3	6	6	6007-0034	HEX HEAD SCREW 5/16-18 UNC-2A X 3/4"
4	6	6	6024-0050	LOCK WASHER 5/16"
5	6	6	6013-0275	HEX NUT 5/16-18 UNC-2B
6	1		1930-C143-0A	HANDRAIL ASSEMBLY
		1	1930-C450-0A	HANDRAIL ASSEMBLY (6856)
7	1	1	758C	DIGITAL INDICATOR
8	1	1	0033-B164-08	MOUNTING BRACKET
9	4	4	6021-0665	MACHINE SCREW #6-32 X .375 PAN HD PHILLIP DR
10	1	1	391RV204	ELASTIC STOP NUT
11	1	1	6680-1043	GROMMET
12	1	1	1930-B336-1A	COLUMN ASSEMBLY
13	1		1930-C337-08	COVER
			1930-C451-08	COVER (6856)
14	1	1	6024-0047	EXT STAR WASHER 1/4"
15	1	1	6007-0007	HEX HEAD SCREW 1/4-20 UNC-2A X 3/8"
16	1	1	0033-B110-08	UHMW DISK
17	1	1	6024-0004	FLAT WASHER 1/4" DIA SS
18	1	1	1930-B428-01	CABLE
19	1	1	6021-1454	HEX HEAD BOLT 1/4-20 UNC-2A X 3/4"
20	1	1	0033-C090-0A	WHEEL ASSY.
21	2	2	6013-0045	HEX NUT 1/4-20 UNC
	1	1	3502-C205-0A	TRIM BOARD

